



INTERNATIONAL APPLICATION PUBLISHED UNDER THE PATENT COOPERATION TREATY (PCT)

(51) International Patent Classification ⁶ : A61B 17/14	A1	(11) International Publication Number: WO 97/42882 (43) International Publication Date: 20 November 1997 (20.11.97)
--	-----------	---

(21) International Application Number: PCT/US97/08399
 (22) International Filing Date: 16 May 1997 (16.05.97)

(30) Priority Data:

60/017,133	17 May 1996 (17.05.96)	US
60/019,918	14 June 1996 (14.06.96)	US
60/023,658	1 August 1996 (01.08.96)	US
60/025,340	3 September 1996 (03.09.96)	US
08/714,548	16 September 1996 (16.09.96)	US
08/710,456	17 September 1996 (17.09.96)	US
08/727,074	8 October 1996 (08.10.96)	US

(71) Applicant: MERCURY DIAGNOSTICS, INC. [US/US]; Suite D, 1137 San Antonio Road, Palo Alto, CA 94303 (US).

(72) Inventors: DOUGLAS, Joel, S.; 2048 Calabazas Boulevard, Santa Clara, CA 95051 (US). ROE, Jeffrey, N.; 3212 Veracruz Drive, San Ramon, CA 94583 (US). RADWANSKI, Ryszard; 16380 Sundance Drive, Morgan Hill, CA 95037 (US). DUCHON, Brent, G.; 410 Milan Drive #106, San Jose, CA 95134 (US).

(74) Agents: DILLAHUNTY, T., Gene et al.; Burns, Doane, Swecker & Mathis, L.L.P., P.O. Box 1404, Alexandria, VA 22313-1404 (US).

(81) Designated States: AL, AM, AT, AU, AZ, BA, BB, BG, BR, BY, CA, CH, CN, CU, CZ, DE, DK, EE, ES, FI, GB, GE, HU, IL, IS, JP, KE, KG, KP, KR, KZ, LC, LK, LR, LS, LT, LU, LV, MD, MG, MK, MN, MW, MX, NO, NZ, PL, PT, RO, RU, SD, SE, SG, SI, SK, TJ, TM, TR, TT, UA, UG, UZ, VN, ARIPO patent (GH, KE, LS, MW, SD, SZ, UG), Eurasian patent (AM, AZ, BY, KG, KZ, MD, RU, TJ, TM), European patent (AT, BE, CH, DE, DK, ES, FI, FR, GB, GR, IE, IT, LU, MC, NL, PT, SE), OAPI patent (BF, BJ, CF, CG, CI, CM, GA, GN, ML, MR, NE, SN, TD, TG).

Published
 With international search report.

(54) Title: METHODS AND APPARATUS FOR SAMPLING AND ANALYZING BODY FLUID

(57) Abstract

A sampling device (10) for sampling body fluid includes a lancet (12) for making an incision, a capillary tube (18) for drawing up body fluid from the incision, and a test strip (30) affixed to an upper end of the capillary tube (18) for receiving the fluid. An absorbent pad (60) can be disposed between the test strip (30) and capillary tube (18) for spreading out the fluid being transferred to the test strip (30). An on site analyzer such as an optical analyzer (44) and/or an electrochemical analyzer (50) can be mounted in the device for analyzing the fluid. Alternatively, a test strip (30) can be slid through a slot formed in the bottom end of the device so that by passing the device against the skin after an incision has been formed. The test strip (30) will directly contact body fluid emanating from the incision.

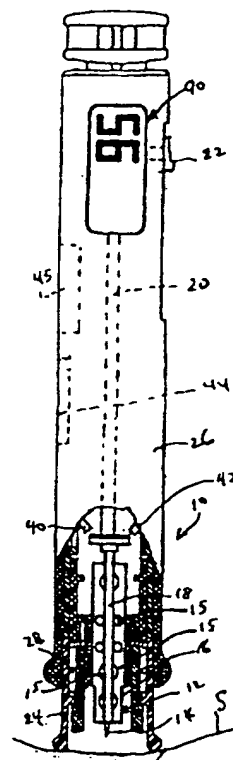

FOR THE PURPOSES OF INFORMATION ONLY

Codes used to identify States party to the PCT on the front pages of pamphlets publishing international applications under the PCT.

AL	Albania	ES	Spain	LS	Lesotho	SI	Slovenia
AM	Armenia	FI	Finland	LT	Lithuania	SK	Slovakia
AT	Austria	FR	France	LU	Luxembourg	SN	Senegal
AU	Australia	GA	Gabon	LV	Latvia	SZ	Swaziland
AZ	Azerbaijan	GB	United Kingdom	MC	Monaco	TD	Chad
BA	Bosnia and Herzegovina	GE	Georgia	MD	Republic of Moldova	TG	Togo
BB	Barbados	GH	Ghana	MG	Madagascar	TJ	Tajikistan
BE	Belgium	GN	Guinea	MK	The former Yugoslav Republic of Macedonia	TM	Turkmenistan
BF	Burkina Faso	GR	Greece	ML	Mali	TR	Turkey
BG	Bulgaria	HU	Hungary	MN	Mongolia	TT	Trinidad and Tobago
BJ	Benin	IE	Ireland	MR	Mauritania	UA	Ukraine
BR	Brazil	IL	Israel	MW	Malawi	UG	Uganda
BY	Belarus	IS	Iceland	MX	Mexico	US	United States of America
CA	Canada	IT	Italy	NE	Niger	UZ	Uzbekistan
CF	Central African Republic	JP	Japan	NL	Netherlands	VN	Viet Nam
CG	Congo	KE	Kenya	NO	Norway	YU	Yugoslavia
CH	Switzerland	KG	Kyrgyzstan	NZ	New Zealand	ZW	Zimbabwe
CI	Côte d'Ivoire	KP	Democratic People's Republic of Korea	PL	Poland		
CM	Cameroon	KR	Republic of Korea	PT	Portugal		
CN	China	KZ	Kazakstan	RO	Romania		
CU	Cuba	LC	Saint Lucia	RU	Russian Federation		
CZ	Czech Republic	LI	Liechtenstein	SD	Sudan		
DE	Germany	LK	Sri Lanka	SE	Sweden		
DK	Denmark	LR	Liberia	SG	Singapore		
EE	Estonia						

METHODS AND APPARATUS FOR SAMPLING
AND ANALYZING BODY FLUID

Field of the Invention

The present invention relates to lancing
5 devices and methods for obtaining samples of blood and
other fluids from the body for analysis or processing.

Background of the Invention

Many medical procedures in use today require
a relatively small sample of blood, in the range of
10 5-50 μ L. It is more cost effective and less traumatic
to the patient to obtain such a sample by lancing or
piercing the skin at a selected location, such as the
finger, to enable the collection of 1 or 2 drops of
blood, than by using a phlebotomist to draw a tube of
15 venous blood. With the advent of home use tests such as
self monitoring of blood glucose, there is a requirement
for a simple procedure which can be performed in any
setting by a person needing to test.

Lancets in conventional use generally have a
20 rigid body and a sterile needle which protrudes from one
end. The lancet may be used to pierce the skin, thereby
enabling the collection of a blood sample from the
opening created. The blood is transferred to a test
device or collection device. Blood is most commonly
25 taken from the fingertips, where the supply is generally
excellent. However, the nerve density in this region
causes significant pain in many patients. Sampling of
alternate site, such as earlobes and limbs, is sometimes
practiced to access sites which are less sensitive.
30 These sites are also less likely to provide excellent
blood samples and make blood transfer directly to test
devices difficult.

Repeated lancing in limited surface areas (such
as fingertips) results in callous formation. This leads

to increased difficulty in drawing blood and increased pain.

To reduce the anxiety of piercing the skin and the associated pain, many spring loaded devices have
5 been developed. The following two patents are representative of the devices which were developed in the 1980's for use with home diagnostic test products.

U.S. Patent No. 4,503,856, Cornell et al., describes a spring loaded lancet injector. The reusable
10 device interfaces with a disposable lancet. The lancet holder may be latched in a retracted position. When the user contacts a release, a spring causes the lancet to pierce the skin at high speed and then retract. The speed is important to reduce the pain associated with
15 the puncture.

Levin et al. U.S. Patent No. 4,517,978 describes a blood sampling instrument. This device, which is also spring loaded, uses a standard disposable lancet. The design enables easy and accurate
20 positioning against a fingertip so the impact site can be readily determined. After the lancet pierces the skin, a bounce back spring retracts the lancet to a safe position within the device.

In institutional settings, it is often
25 desirable to collect the sample from the patient and then introduce the sample to a test device in a controlled fashion. Some blood glucose monitoring systems, for example, require that the blood sample be applied to a test device which is in contact with a test
30 instrument. In such situations, bringing the finger of a patient directly to the test device poses some risk of contamination from blood of a previous patient. With such systems, particularly in hospital settings, it is common to lance a patient, collect a sample in a

micropipette via capillary action and then deliver the sample from the pipette to the test device.

Haynes U.S. Patent No. 4,920,977 describes a blood collection assembly with lancet and
5 microcollection tube. This device incorporates a lancet and collection container in a single device. The lancing and collection are two separate activities, but the device is a convenient single disposable unit for situations when sample collection prior to use is
10 desirable. Similar devices are disclosed in Sarrine U.S. Patent No. 4,360,016, and O'Brien U.S. Patent No. 4,924,879. Jordan et al. U.S. Patents No. 4,850,973 and No. 4,858,607, disclose a combination device which may be alternatively used as a syringe-type injection
15 device and a lancing device with disposable solid needle lancet, depending on configuration. Lange et al. U.S. Patent No. 5,318,584 describes a blood lancet device for withdrawing blood for diagnostic purposes. This invention uses a rotary/sliding transmission system to
20 reduce the pain of lancing. The puncture depth is easily and precisely adjustable by the user.

Suzuki et al. U.S. Patent No. 5,368,047, Dombrowski U.S. Patent No. 4,654,513 and Ishibashi et al. U.S. Patent No. 5,320,607 each describe suction-type
25 blood samplers. These devices develop suction between the lancing site and the end of the device when the lancet holding mechanism withdraws after piercing the skin. A flexible gasket around the end of the device helps seal the end around the puncture site until
30 adequate sample is drawn from the puncture site or the user pulls back on the device.

Garcia et al. U.S. Patent No. 4,637,403 discloses a combination lancing and blood collection device which uses a capillary passage to conduct body
35 fluid to a separate test strip in the form of a

microporous membrane. It is necessary to achieve a precise positioning of the upper end of the capillary passage with respect to the membrane in order to ensure that body fluid from the passage is transferred to the membrane. If an appreciable gap exists therebetween, no transfer may occur.

Also, the diameter of the capillary passage is relatively small, so the width of a sample transferred to the membrane may be too small to be measured by on-site measuring devices such as an optical measuring system or an electrochemical meter.

It is difficult for a user to determine whether a sufficiently large drop of body fluid has been developed at the incision for providing a large enough sample.

International Publication Number WO95/10223, Erickson et al., describes a means of collecting and measuring body fluids. This system uses a disposable lancing and suction device with a spacer member which compresses the skin around the lance/needle.

Single use devices have also been developed for single use tests, i.e. home cholesterol testing, and for institutional use to eliminate cross-patient contamination multi-patient use. Crossman et al. U.S. Patent No. 4,869,249, and Swierczek U.S. Patent No. 5,402,798, also disclose disposable, single use lancing devices.

The disclosures of the above patents are incorporated herein by reference.

An object of the present invention is to ensure that a sufficiently large drop of body fluid is developed at an incision, and that the body fluid reaches a test strip.

Another object is to ensure that the sample applied to the test strip creates a measurement area that is sufficiently wide to be properly analyzed.

5 An additional object is to provide a novel electrochemical analyzing system for analyzing a sample in the lancing device.

A further object is to enable a sample of body fluid to be applied to a test strip which is mounted in a lancing device.

10 Another object of this invention is to provide a method which can result in a sample of either blood or interstitial fluid, depending on the sample site and the penetration depth utilized. While there are no commercially available devices utilizing interstitial
15 fluid (ISF) at this time, there are active efforts to establish the correlation of analytes, such as glucose, in ISF compared to whole blood. If ISF could be readily obtained and correlation is established, ISF may be preferable as a sample since there is no interference of
20 red blood cells or hematocrit adjustment required.

Another object of this invention is to provide a method which can draw a small but adjustable sample, i.e. 3 μ L for one test device and 8 μ L for another test device, as appropriate.

25 Another object of this invention is to provide a method by which the drawn sample is collected and may be easily presented to a testing device, regardless of the location of the sample site on the body. This approach helps with infection control in that multiple
30 patients are not brought in contact with a single test instrument; only the sampling device with a disposable patient-contact portion is brought to the test instrument. Alternatively, the disposable portion of a test device may be physically coupled with the sampler
35 so the sample can be brought directly into the test

device during sampling. The test device may then be read in a test instrument if appropriate or the testing system can be integrated into the sampler and the test device can provide direct results displayed for the patient.

A further object is to provide an on-site test strip with a relatively wide sample which can be analyzed by on-site analyzers such as optical and electrochemical analyzers.

It is a further object of the invention to provide a device for minimally invasive sampling comprising a reusable sampler and disposable sample collection.

Summary of the Invention

One aspect of the present invention relates to a sampling device for sampling body fluid. The device includes a housing and a lancet carrier mounted in the housing for supporting a disposable lancet. The device also includes a mechanism for displacing the lancet carrier toward a lower end of the housing for forming an incision in a user. A body fluid sampling member is mounted in the housing for conducting body fluid from the incision. That sampling member comprises a capillary member, and a test strip. The capillary member includes an elongated stem having a capillary passage extending longitudinally therethrough for conducting body fluid upwardly by capillary action. The test strip is affixed to the capillary member at an upper end thereof and in communication with the capillary passage for receiving a sample of body fluid.

Preferably, the test strip comprises a microporous membrane, and an absorbent pad is preferably disposed between the test strip and the upper end of the

capillary passage for wicking body fluid from the passage to the test strip.

The present invention also relates to the capillary member *per se*.

5 Another embodiment of the sampling device includes a housing, a lancet carrier mounted in the housing for supporting a disposable lancet, a mechanism for displacing the lancet carrier toward a lower end of the housing for forming an incision in a user, and a
10 strip-holding mechanism mounted at a lower end of the housing for supporting a test strip across the lower end of the housing to enable the test strip to pick up body fluid from the incision.

The strip holding mechanism preferably
15 comprises a sleeve disposed in surrounding relationship to the lancet carrier and includes radially aligned slots for receiving a test strip.

Preferably, the sleeve constitutes a first sleeve, and the holding mechanism further includes a
20 second sleeve surrounding the first sleeve and including slots that are radially aligned with the slots of the first sleeve. The second sleeve is slidable longitudinally relative to both the housing and the first sleeve and is spring biased downwardly. The slots
25 which are formed in the second sleeve are elongated in a direction parallel to a longitudinal axis of the housing to enable the second sleeve to move longitudinally relative to a test strip mounted in the first sleeve.

The present invention also relates to a method
30 of sampling body fluid which comprises the steps of positioning a lower end of a sampling device against a skin surface, and displacing a lancet carrier toward the lower end of the sampling device to form an incision through the skin. A test strip is positioned in the
35 sampling device to extend across the lower end thereof.

The sampling device is moved toward the incision to bring the test strip into contact with body fluid emerging from the incision. The test strip is preferably positioned in the sampling device prior to the displacement of the lancet toward the lower end of the sampling device, whereby the lancet pierces the test strip.

Another aspect of the invention involves the provision of a drop-detecting mechanism on the lancing device adjacent a lower end thereof for detecting a drop of body fluid on the user's skin. The mechanism can be in the form of electrodes which contact the drop, or an optical system including a light emitter and a light sensor. The drop-detecting mechanism automatically determines whether a drop of sufficient size has been developed at the incision for providing a proper sample.

Brief Description of the Drawing

The objects and advantages of the invention will become apparent from the following detailed description of preferred embodiments thereof in connection with the accompanying drawing in which like numerals designate like elements and in which:

Fig. 1 is a side elevational view, partially broken away, of a blood sampling device according to the present invention, with a capillary tube thereof disposed in a retracted state;

Fig. 2 is a view similar to Fig. 1 after an incision has been made, and the capillary tube has been extended;

Fig. 3 is a longitudinal sectional view through one embodiment of the capillary tube according to the present invention;

Fig. 4 is a longitudinal sectional view taken through another embodiment of a capillary tube according to the present invention;

Fig. 5 is view similar to Fig. 2 of a sampling device having an alternative form of analyzing instrument;

Fig. 6 is a fragmentary view of a lower end of a lancing device, depicting a drop-detecting mechanism according to the present invention;

Fig. 7 is a side elevational view, partially broken away of another embodiment of the sampling device, with a test strip mounted at a lower end thereof; and

Fig. 8 is a fragmentary view of the device depicted in Fig. 6 in a sampling-taking state.

Detailed Description of Preferred Embodiments of the Invention

Depicted in Figs. 1 and 2 is a lancing device 10 for making an incision through a skin surface S, wherein a disposable lancet 12 (hereinafter referred to as a "disposable") which carries a skin-lancing member in the form of a needle 14 can be displaced toward the skin surface by a cocked spring and then rapidly retracted by another spring. Devices of this general type are known, and one preferred device is disclosed in commonly assigned, concurrently filed U.S. application Serial

No. _____ (Attorney Docket 018176-039), the disclosure of which is incorporated herein by reference.

As disclosed in that application, the disposable 12 includes a body 16 which carries not only the needle 14, but also a capillary tube 18. The capillary tube is mounted by friction fit between holding elements 15 that are integral with the body 16

and is downwardly slidable relative to the body 16 in response to manual downward displacement of a pusher 20 which possesses an exposed actuator knob 22.

The disposable 12 is situated telescopingly
5 within a cylindrical stimulator sleeve 24 which is slidable longitudinally relative to a housing 26 of the device. The sleeve 24 is biased downwardly, or forwardly, by a spring 28. Following the cutting of an incision I in the skin and the retraction of the lancet,
10 the housing can be repeatedly pushed downwardly against the skin as required to express the appropriate sample from the incision, whereupon the sleeve depresses a ring of body tissue in surrounding relationship to the incision, causing the incision to bulge while spreading
15 apart the sides of the incision. Consequently, a drop D of body fluid such as blood or interstitial fluid is formed at the open end of the incision, even if the incision I has been made in a region of the body where the supply of body fluid is relatively low as compared
20 to, say, the fingertip region.

Once the drop D has been created, the pusher 22 is displaced to push the capillary tube downwardly to a state where the lower end of the capillary tube can be dipped into the body fluid drop to obtain a sample.
25 The pusher is then released for return to an upper position by a return spring (not shown). As disclosed in the aforementioned application, the fluid can then be transferred from the capillary tube to a test strip, thereby making the overall sampling procedure more
30 convenient.

In accordance with the present invention, the sampling procedure is made even more convenient by eliminating the need to transfer the body fluid from the capillary tube.

In a first embodiment, the capillary tube carries its own test strip. Depicted in Fig. 3 is a test strip 30 in the form of a microporous membrane (preferably of the type disclosed in commonly assigned
5 U.S. application Serial No. 08/628,489, filed April 5, 1996, the disclosure of which is incorporated by reference herein).

The membrane 30 is bonded, e.g. by a suitable adhesive, to an enlarged head or flange portion 32 of
10 the capillary tube 18 which projects laterally with respect to a stem portion 34 of the capillary tube. The head 32, when viewed from the top, can be of any shape, such as circular or rectangular (e.g., square). A capillary passage 36 extends longitudinally through the
15 stem 34 and head 32 to conduct body fluid into contact with the membrane by capillary action.

As is known in the art of capillary tubes, the amount of body fluid which is drawn up by capillary action can be regulated by a suitable selection of
20 diameter and length of the passage 36, thereby ensuring that a proper dosing of the membrane is achieved.

Fluid analyzing instruments can be mounted within the housing. For example, a conventional optical analyzing mechanism can be provided which includes a
25 light source 40 and a light sensor 42 such as a phototransistor, which are electrically connected to a conventional electronics unit 44 for monitoring a color change of the sample as the sample reacts with chemicals in the test strip. The electronics unit 44 displays the
30 results on a display panel 90. In that way, for example, the glucose level in blood can be measured. The unit 44 is electrically connected to a battery 45 that is mounted in the housing.

In lieu of an optical analyzing mechanism, an
35 electrochemical mechanism can be provided in a device

10' (Fig. 5), the mechanism including an electrochemical meter 50 which measures glucose levels. The meter 50 is electrically connected to a battery 51 mounted in the housing. The test strip 52 in this case would be
5 provided with a printed electrical circuit, and the pusher 24' would possess electrical leads 54 positioned so as to contact respective portions of the printed circuit electrical paths on the test strip when the
10 pusher 24' is in its lower position (after having pushed the capillary tube down). Thus, the sample conducted to the test strip 52 by the capillary tube will contact the electrical circuit for conducting a current therebetween when the leads 54 are brought into contact with the
15 circuit. The leads are connected to the meter 50 which measures the current. Since the level of current is proportional to the glucose concentration, the meter 50 is able to measure that concentration.

When the disposable 12 is discarded after a testing operation, the capillary tube 18 and test strip
20 30 will be discarded therewith. A fresh disposable is then installed to present a new lancet 14, capillary tube 18 and test strip 30. Thus, the user never has to touch or otherwise maneuver a test strip separately from the capillary tube, since the test strip is attached
25 thereto.

An alternate embodiment of a capillary tube 18' is depicted in Fig. 4 wherein an absorbent pad 60 is disposed between the test strip 30 and the head 32' of the capillary tube 18'. That is, the absorbent pad,
30 which can be formed of cellulose or suitable membrane, is bonded to the capillary tube 18', and the membrane 30 is bonded to the absorbent pad, or to a ring 62 which extends around a circumferential outer edge face of the absorbent pad 60. That ring, together with the flange
35 32, forms a cover which covers portions of the absorbent

pad not covered by the membrane 30 to prevent the escape of the body fluid sample. When the capillary tube draws-up body fluid by capillary action, that fluid is wicked by the absorbent pad and supplied to the test strip 30. An advantage of the capillary tube 18' is that the absorbent pad will spread-out the fluid so that a wider sample is applied to the test strip to facilitate analysis.

A backpressure may occur which opposes a flow of body fluid through the absorbent pad 60. To deal with that potential problem, the head 32' is provided with air vent openings 64 to relieve the backpressure and facilitate the flow of fluid through the pad 60. The air vents are spaced laterally from the passage 36 and communicate with the pad. The diameter of the vent openings is smaller than that of the capillary tube and small enough to prevent the passage of body fluid therethrough.

Instead of being bonded directly to the absorbent pad 60, the membrane 30 could be bonded to the cover 62. In that case, the absorbent pad 60 could be bonded to the membrane, or to the cover, or to the capillary tube.

In any event it will be appreciated that the test strip is affixed, either directly or indirectly, to the capillary tube to constitute an integral part thereof.

One problem faced by a user is being able to determine whether a drop of body fluid expressed from an incision is of sufficient size to provide a proper sample. That determination can be made automatically by a sampling device 10" in accordance with an embodiment of the invention depicted in Fig. 6 wherein a drop sensing mechanism 65 is mounted on an inner sleeve 66. The drop sensing mechanism comprises a pair of

diametrically opposed elements 67, 68. In one embodiment, those elements comprise a pair of electrodes connected by wires 69 to the battery 45 or 51 and positioned such that when the outer sleeve 24 is retracted in response to a pressing down of the housing, the electrodes will make contact with the drop of body fluid only if the drop is of sufficient height to provide an adequate sample. If such contact is made, the drop will close a circuit, enabling a sensor to determine that the drop is of ample size. An indicator, such as a lamp 71 can be energized to advise the user.

Alternatively, the elements 67, 68 of the mechanism 65 could comprise a light emitter and light receiver, respectively. When the drop of body fluid is of sufficient height, it will block the transmission of light to the receiver, thus indicating that the drop is of sufficient size, and triggering the energization of the lamp 71.

The drop-detecting mechanism 65 can be used with either of the embodiments disclosed in connection with Figs. 1-2 and 5. However, it is not necessary that the incision be formed by a lancet. Other incision forming devices could be used such as a laser beam or pressurized fluid. That is, known pneumatic or hydraulic injectors of the type which inject pressurized gas or liquid against the skin could be used. such auto injectors are sold by Becton-Dickinson, for example, to inject insulin. By eliminating the insulin and merely injecting the gas (e.g., air or nitrogen) or liquid (e.g., water) at pressures about 30 psi. an incision could be formed in the skin for taking samples of body fluid. Advantageously, small particles could be mixed with the gas to promote the tissue-cutting action. The particles could comprise carbon particles of from 1 micron to 0.010 inches in diameter.

Another embodiment of a sampling device 10" according to the invention is depicted in Figs. 7 and 8. In that embodiment, the stimulator sleeve 24" is provided with a through-slot 70, and an inner sleeve 72 (which supports the disposable), is provided with a through-slot 74 that is aligned with the through-slot 70. Those aligned through-slots 70, 74 are adapted to receive a test strip 30" which, if desired, includes an absorbent pad 60". The test strip 30", which may comprise a porous membrane 30A" and an absorbent pad 30B" attached thereto, is manually inserted through the slots 70, 74 by the user.

When a lancing procedure is performed, the lancet pierces the test strip 30" en route to the skin surface. Then, as the housing is repeatedly pushed down to pump body fluid to the open end of the incision as described earlier, the stimulator sleeve 24" will be repeatedly retracted, and simultaneously the inner sleeve 72, along with the test strip 30", will approach and contact the drop of body fluid as shown in Fig. 8, whereby a sample of the fluid is collected on the test strip. Then, the user removes the test strip for testing at an off-site analyzer.

It will be appreciated that the present invention enables a test strip to be easily installed into and removed from a lancing device, thereby minimizing any risk of contamination of the sample. In the examples according to Figs. 1-5 the test strip is installed along with the disposable lancet, thereby being automatically positioned in proper relationship to receive a sample and to permit the sample to be analyzed by an on-side analyzing instrument. If desired, however, the analysis could be performed by an off-site instrument by removing the disposable from the device and taking it to the off-site instrument. In the

example of Figs. 7-8, the test strip is easily installed/removed by being passed through readily accessible slots.

Although the present invention has been
5 described in connection with preferred embodiments thereof, it will be appreciated by those skilled in the art that additions, modifications, substitutions and deletions not specifically described may be made without departing from the spirit and scope of the invention as
10 defined in the appended claims.

CLAIMS:

1. A sampling device for sampling body fluid,
comprising:

a housing;

5 a lancet carrier mounted in the housing and
adapted for supporting a disposable lancet;

a mechanism disposed in the housing for
displacing the lancet carrier toward a lower
end of the housing for forming an incision
10 through the skin of a user; and

a body fluid sampling member mounted in the
housing for conducting body fluid from the
incision, comprising

15 a capillary member including an elongated
stem having a capillary passage extending
longitudinally therethrough for
conducting body fluid upwardly by
capillary action, and

20 a test strip affixed to the capillary
member at an upper end thereof and in
communication with the capillary passage
for receiving a sample of body fluid
therefrom.

2. The sampling device according to claim 1
25 wherein the test strip comprises a microporous membrane.

3. The sampling device according to claim 1 wherein the sampling member further comprises an absorbent pad disposed between the test strip and the upper end of the capillary passage for wicking body fluid from the passage to the test strip.

4. The sampling device according to claim 3 wherein the pad is affixed directly to the capillary member, and the test strip is affixed directly to the pad.

5. The sampling device according to claim 1 wherein the disposable element includes a body, the sampling member being mounted in the body.

6. The sampling device according to claim 5 wherein the sampling member is slidable relative to the body, the housing including a manually actuatable pusher for pushing the sampling member downwardly.

7. The sampling device according to claim 6, further including an optical analyzing mechanism disposed in the housing and arranged to analyze body fluid disposed on the test strip.

8. The sample device according to claim 7 wherein the optical analyzing mechanism comprises a light emitter for directing light toward body fluid disposed on the test strip, and a light receiver for receiving light reflected off the sample.

9. The sampling device according to claim 6, further including an electrochemical analyzing mechanism mounted in the housing, the pusher carrying electrical leads arranged for making electrical connection with a body fluid sample on the test strip, the leads being
5 electrically connected to the analyzing mechanism.

10. The sampling device according to claim 1, further including an electrochemical analyzing meter mounted in the housing, a manually movable element
10 mounted in the housing and carrying electrical leads arranged to make electrical connection with the meter.

11. The sampling device according to claim 1 further including a drop detecting mechanism disposed adjacent a lower end of the device for detecting a drop
15 of body fluid disposed on the user's skin.

12. The sampling device according to claim 11 wherein the drop detecting mechanism includes a pair of spaced apart electrodes arranged to contact the drop and provide a signal to an indicator.

20 13. The sampling device according to claim 11 wherein the drop detecting mechanism comprises a light emitter and light receiver disposed adjacent a lower end of the device and provide a signal to an indicator.

14. A sampling device for sampling body fluid, comprising:

a housing;

5 a lancet carrier mounted in the housing and adapted for supporting a disposable lancet;

a mechanism for displacing the lancet carrier toward a lower end of the housing for forming an incision through the skin of a user; and

10 a strip-holding mechanism mounted at a lower end of the housing for supporting a test strip across the lower end of the housing to enable the test strip to pick-up body fluid from the incision.

15 15. The sampling device according to claim 14 wherein the strip-holding mechanism comprises a sleeve surrounding the lancet carrier and including slots for receiving the test strip.

20 16. The sampling device according to claim 15 wherein the sleeve constitutes a first sleeve, the strip-holding mechanism further including a second sleeve surrounding the first sleeve and including slots radially aligned with the slots of the first sleeve, the second sleeve being slidable longitudinally relative to both the housing and the first sleeve and being spring
25 biased downwardly, the slots formed in the second sleeve being elongated in a direction parallel to a longitudinal axis of the housing to enable the second

sleeve to move longitudinally relative to a test strip mounted in the first sleeve.

17. A sampling device for sampling body fluid, comprising:

5 a housing;

means in the housing for forming an incision through the skin of a user; and

10 a drop-detecting mechanism disposed adjacent a lower end of the device for detecting a drop of body fluid disposed on the user's skin.

18. The sampling device according to claim 17, further including an indicator mounted on the housing and connected to the drop-detecting mechanism for providing an indication to a user when a detected drop is of predetermined size.

19. The sampling device according to claim 17 wherein the drop detecting mechanism includes a pair of spaced apart electrodes arranged to contact the drop.

20. The sampling device according to claim 17 wherein the drop detecting mechanism comprises a light emitter and light receiver disposed adjacent a lower end of the device.

21. A method of sampling body fluid comprising the steps of:

25 A) positioning a lower end of a sampling device against a skin surface;

22

B) displacing a lancet toward the lower end of the sampling device to form an incision through the skin;

5 C) mounting a test strip in the sampling device to extend across the lower end thereof; and

D) moving the sampling device toward the incision to bring the test strip into contact with body fluid emerging from the incision.

10 22. The method according to claim 21 wherein step C is performed prior to step B whereby the lancet pierces the test strip when displaced to form the incision.

15 23. The method according to claim 21 wherein step C comprises sliding the test strip through a radial slot formed in the device.

24. A body fluid sampling member adapted to be mounted in a device for sampling body fluid, comprising:

20 a capillary member including an elongated stem having a capillary passage extending longitudinally therethrough for conducting body fluid upwardly by capillary action; and

25 a test strip affixed to the capillary member at an upper end thereof and in communication with the capillary passage for receiving a sample of body fluid.

25. The body fluid sampling member according to claim 24 wherein the test strip comprises a microporous membrane.

5 26. The body fluid sampling member according to claim 25 further comprising an absorbent pad disposed between the test strip and the upper end of the capillary member and arranged over the capillary passage for wicking body fluid from the passage to the test strip.

10 27. The body fluid sampling member according to claim 26 wherein the absorbent pad is affixed directly to the capillary member, and the test strip is affixed directly to the absorbent pad.

15 28. The body fluid sampling member according to claim 26 further including a covering structure covering portions of the absorbent pad not covered by the membrane; the covering structure being vented by at least one air vent opening having a smaller cross section than the passage.

20 29. The body fluid sampling member according to claim 28 wherein the covering structure includes a flange projecting laterally outwardly from an upper end of the stem, a lower surface of the pad being seated on the flange.

25 30. The body fluid sampling member according to claim 29 wherein the covering structure further includes a side cover extending around a side surface of the pad.

31. the body fluid sampling member according to claim 30 wherein the air vent opening is disposed in the flange.

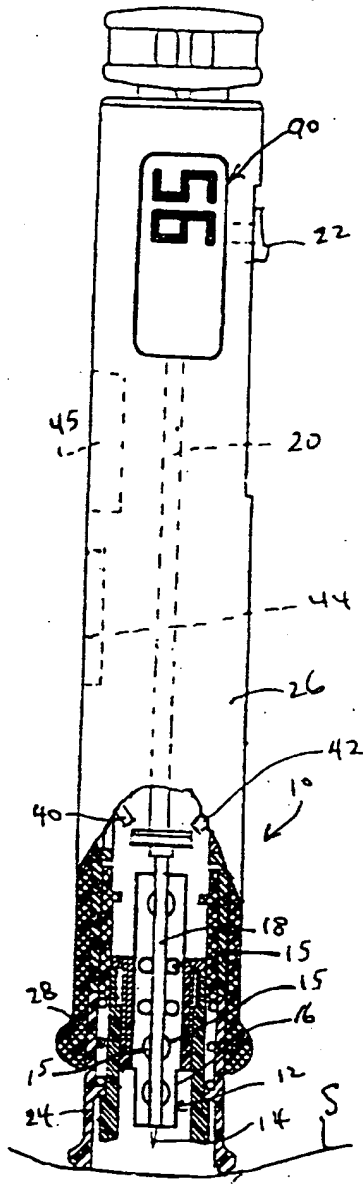

FIG. 1

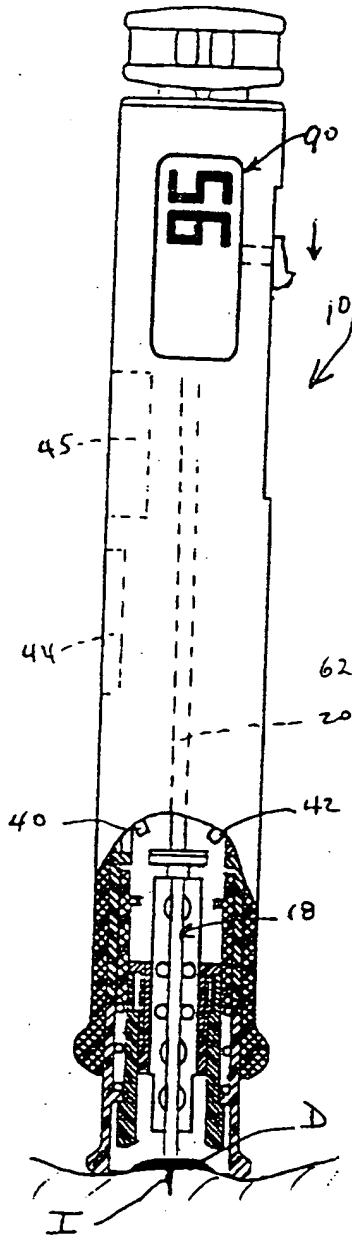

FIG. 2

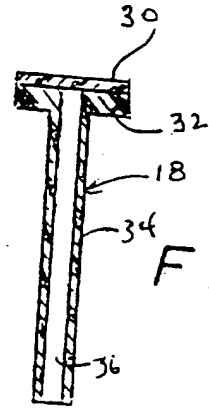

FIG. 3

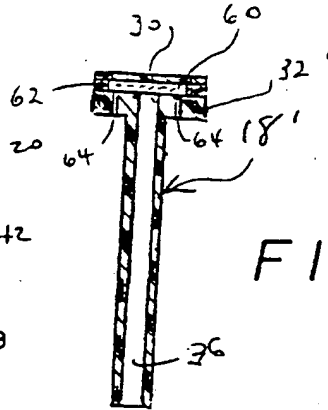

FIG. 4

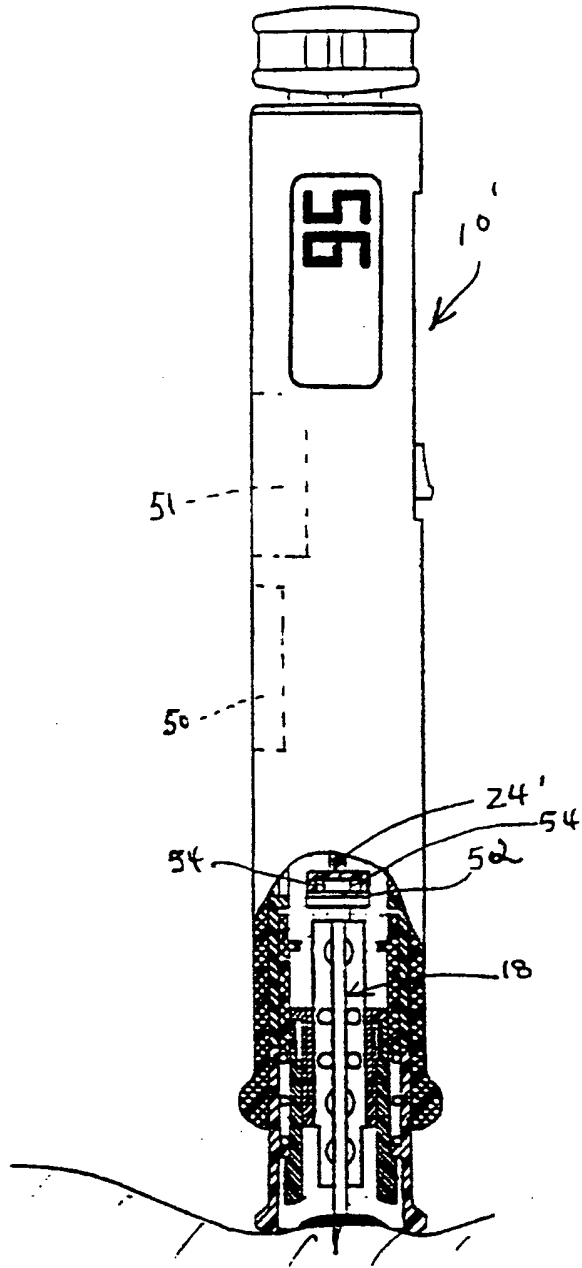

FIG. 5

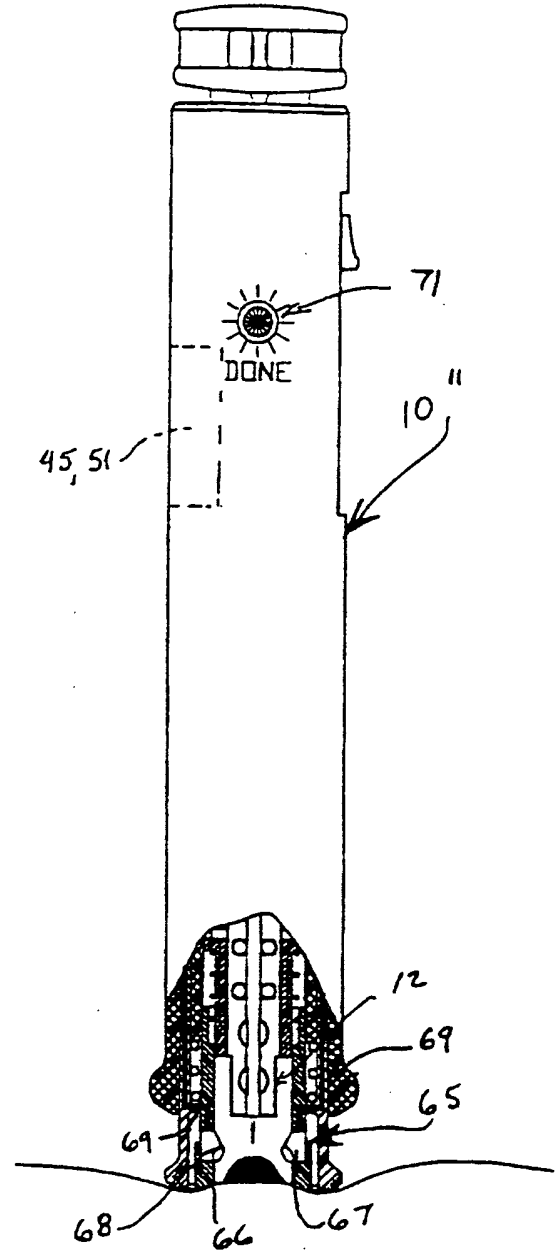

FIG. 6

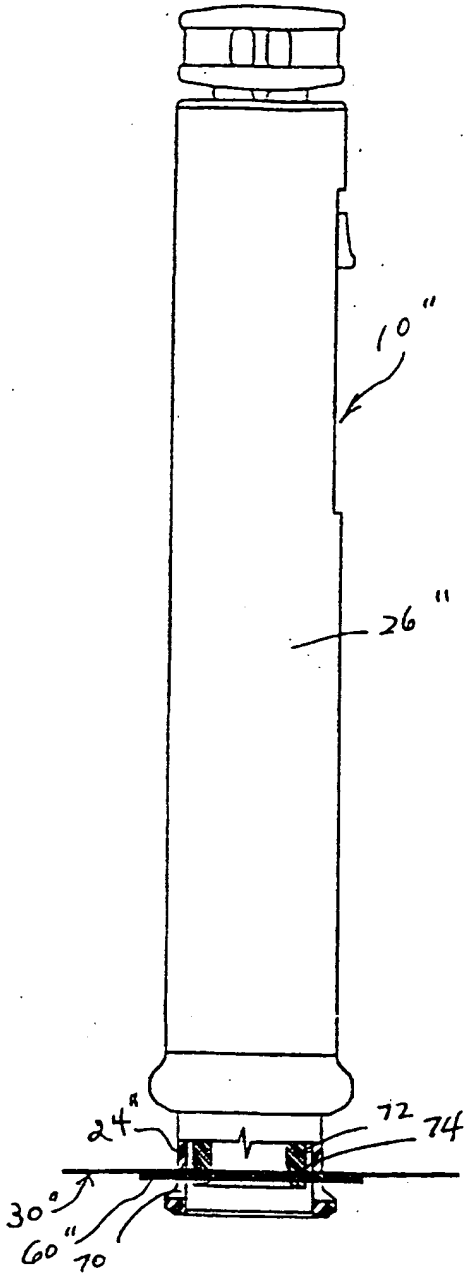

FIG. 7

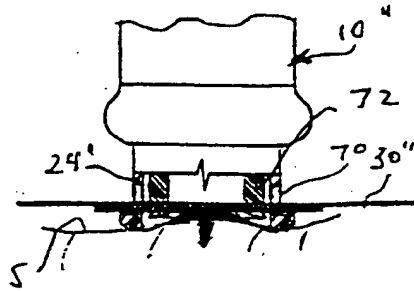

FIG. 8

INTERNATIONAL SEARCH REPORT

International application No.
PCT/US97/08399

A. CLASSIFICATION OF SUBJECT MATTER		
IPC(6) :A61B 17/14 US CL :606/181 According to International Patent Classification (IPC) or to both national classification and IPC		
B. FIELDS SEARCHED		
Minimum documentation searched (classification system followed by classification symbols) U.S. : 128/633, 636, 760, 770, 771; 606/181, 182		
Documentation searched other than minimum documentation to the extent that such documents are included in the fields searched		
Electronic data base consulted during the international search (name of data base and, where practicable, search terms used) APS		
C. DOCUMENTS CONSIDERED TO BE RELEVANT		
Category*	Citation of document, with indication, where appropriate, of the relevant passages	Relevant to claim No.
X	US 4,637,403 A (GARCIA et al) 20 January 1987, entire document.	1-10, 14, 15, 21-27
X	US 4,924,879 A (O'BRIEN) 15 May 1990, col. 3, lines 25-34.	17, 18
A	US 5,279,294 A (ANDERSON et al) 18 January 1994, entire document.	1-31
A	US 5,029,583 A (MESEROL et al) 09 July 1991, entire document.	1-31
<input type="checkbox"/> Further documents are listed in the continuation of Box C. <input type="checkbox"/> See patent family annex.		
* Special categories of cited documents:		
A document defining the general state of the art which is not considered to be of particular relevance		*T* later document published after the international filing date or priority date and not in conflict with the application but cited to understand the principle or theory underlying the invention
E earlier document published on or after the international filing date		*X* document of particular relevance; the claimed invention cannot be considered novel or cannot be considered to involve an inventive step when the document is taken alone
L document which may throw doubts on priority claim(s) or which is cited to establish the publication date of another citation or other special reason (as specified)		*Y* document of particular relevance; the claimed invention cannot be considered to involve an inventive step when the document is combined with one or more other such documents, such combination being obvious to a person skilled in the art
O document referring to an oral disclosure, use, exhibition or other means		*Z* document member of the same patent family
P document published prior to the international filing date but later than the priority date claimed		
Date of the actual completion of the international search 30 JULY 1997	Date of mailing of the international search report 29 AUG 1997	
Name and mailing address of the ISA/US Commissioner of Patents and Trademarks Box PCT Washington, D.C. 20231	Authorized officer TINA T. D. PHAM <i>Diane Smith for</i>	
Facsimile No. (703) 305-3230	Telephone No. (703) 308-0824	